

Regulatory Information Report

RPF23004

**Fire resistance test for an air duct passing
through a plasterboard wall – Internal fire**

Issued to:	Firestop Centre Ltd
Test method:	AS1530.4-2014
Report Date:	22/01/2024
Valid till:	09/08/2028
Test number:	PF23004



Table of Contents

- 1.1 Document revision schedule 3
- 1.2 Signatories 3
- 2. Report Summary..... 4
- 3. General Information 5
 - 3.1 Testing Scope 5
 - 3.2 Contact Details..... 5
 - 3.3 Timeline 6
 - 3.4 Use of the Report 6
- 4. Specimen Description..... 7
 - 4.1 Supporting Construction..... 7
 - 4.2 Specimen 1 - Duct..... 8
 - 4.3 Specimen 2: Hatch..... 12
- 5. Additional temperature measurements 15
- 6. Permissible variations to the tested specimen 16



1.1 Document revision schedule

Revision #	Date	Description
1	12/12/23	Initial issue for Client review
2	19/01/24	Issued with Client comments
3	22/01/24	Issued with Client comments

1.2 Signatories

Report	Name	Signature	Date
Prepared by:	Alex Kokorin		22/01/24
Authorised by:	Andrew Bain (Authorized signatory)		22/01/24



All tests reported herein have been performed in accordance with the laboratory's scope of accreditation

2. Report Summary

An 800mm x 800mm (W/H) air duct was installed, penetrating through a 90x45mm timber stud wall, with 2 x layer of FR plasterboard on each side. The supporting construction aperture was protected using a combination of acrylic sealant, ceramic fibre, steel brackets, and FR board. The duct was protected using 38mm thick FIRESTOP Duct Wrap-38, fixed using steel cable ties. The duct included a hatch located 1800mm from the unexposed face of the separating element.

Test results – Duct – internal fire

Structural adequacy	No Failure at 127 minutes
Integrity	No Failure at 127 minutes
Insulation	62 minutes
Fire resistance level (FRL)	120/120/60

Test results – Access hatch

Structural adequacy	Not applicable
Integrity	No Failure at 127 minutes
Insulation	No Failure at 127 minutes
Fire resistance level (FRL)	-/120/120

The conditions of the test complied with AS1530.4-2014 requirements.

There were no major observations related to the performance criteria during the test.

3. General Information

3.1 Testing Scope

Applicable Standards:

AS 1530.4-2014 Section 9 Air ducts – Internal fire

AS 1530.4-2014 Section 10 Service penetrations and control joints

Departures from Testing Method:

No departures from the testing method.

Conditions of the test complied with AS1530.4-2014 requirements.

3.2 Contact Details

Accredited Testing Laboratory

Fire TS Lab - Passive Fire Inspection and Test Services Ltd

Accreditation Number - 1335

1/113 Pavilion Drive, Mangere, Auckland, 2022

New Zealand

Contact e-mail: tests@firelab.co.nz

Issued to:

Firestop Centre Ltd

657 Great South Rd, Penrose, Auckland, 1061

New Zealand

Contact e-mail: info@firestopcentre.co.nz

Manufacturer:

Same as Client/Applicant

3.3 Timeline

Testing date:

10/5/2023

Installation completion date:

5/05/2023

Termination of The Test:

The test was discontinued at 127 minutes.

3.4 Use of the Report

Regulatory information report was issued in addition to full test report PF23004. This provides the minimum information required for regulatory compliance.

The report is valid till 09/08/2028.

This report shall not be reproduced, except in full.

This report details the methods of construction, test conditions and the results obtained when the specific element of construction described herein was tested following the procedure outlined in AS 1530.4. Any significant variation with respect to size, constructional details, loads, stresses, edge or end conditions, other than that allowed under the field of direct application in the relevant test method, is not covered by this report.

Because of the nature of fire resistance testing and the consequent difficulty in quantifying the uncertainty of measurement of fire resistance, it is not possible to provide a stated degree of accuracy of the result.

The test results relate to the specimens of the product in the form in which they were tested. Differences in the composition or thickness of the product may significantly affect the performance during the test and may therefore invalidate the test results. Care should be taken to ensure that any product, which is supplied or used, is fully represented by the specimens, which were tested.

The specimens were supplied by the sponsor and the Laboratory was not involved in any of selection or sampling procedures.

The results of these fire tests may be used to directly assess fire hazard, but it should be recognized that a single test method will not provide a full assessment of fire hazard under all fire conditions.

4. Specimen Description

4.1 Supporting Construction

Separating element		
1.1	Item	90 x 45mm Timber stud wall with two layers of 13mm FR plasterboard each side
	Aperture	860mm x 860mm
		30mm (nominal) annular gap around duct
		Lined with 2 layer of FR plasterboard
	Dimensions	Double timber studs frame (90x90mm total) around aperture
		Width / Height (W/H): 1200mm x 1200mm
		Wall Thickness (T): 142mm
	Cavity: 90mm	

4.2 Specimen 1 - Duct

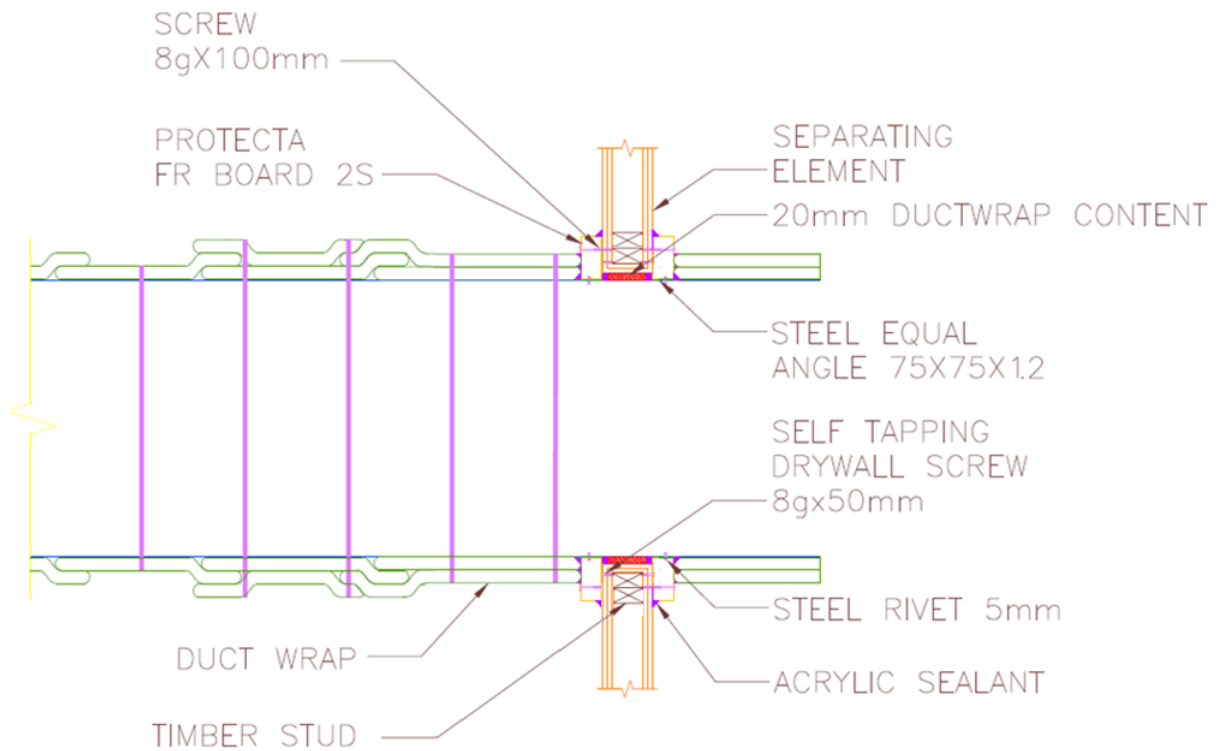

Figure 1a – Duct cross section

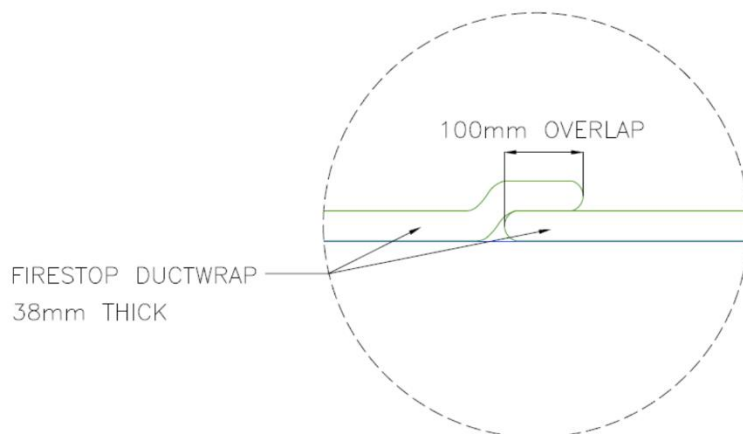

Figure 1c – Detail 2

Specimen		
2.1	Item	Air Duct (as per AS4254.2)
	Measurements	Width / Height / Thickness (W/H/T): 800mm x 800mm x 0.76mm
	Specimen Support	Unistrut structure at 1000mm and 2000mm
	Aperture Size	860mm x 860mm
	Annular Spacing	30mm
	Installation	<p>Symmetrical – Protrudes 480mm from exposed face</p> <p>The annular gap between the duct and separating element was treated with the strip of Duct Wrap content (ceramic wool) installed in annular gap between duct and separating element, recessed 15mm from both faces. The recess was filled with Acrylic sealant to the nominal depth of 15mm. Steel angles were installed flush with the wall and fixed to the duct and the wall. 100mm FR Board collar was installed on the top of the steel angles and fixed to the wall. All joints were sealed with bead of Acrylic sealant.</p> <p>One layer of the duct wrap was installed around the duct having nominal 100mm overlap for the longitudinal and transverse joints. Longitudinal were staggered by minimum 200mm and located minimum 200mm from the edge of the duct.</p> <p>A second layer of wrap was installed using the same overlapping method on top of the first layer. Transverse joints of the first and second layer were staggered by at least 200mm.</p> <p>Each layer of wrap was fixed to the duct using steel cable ties at 150mm from the end of the wrap.</p> <p>The duct was tested open on the fire side.</p>

Wrap		
3.1	Item	FIRESTOP Duct Wrap-38 – foil faced ceramic fibre blanket
	Measurements	Thickness / Width / Length (T/W/L): 38mm x 600mm x 7200mm

	Density	96 kg/m ³
	Installation	<p>Used to wrap the Air duct on unexposed face.</p> <p>1st layer: First length of wrap was trimmed to 400mm width, butting up against the board. The second and third lengths were 600mm width, overlapping the previous length by approximately 100mm.</p> <p>2nd Layer: First length and second length of wrap were 600mm width. First length was butting up against the board, second layer overlapping the previous by approximately 100mm.</p>

Board		
4.1	Item	Protecta FR Board 2S
	Measurements	Length / Width (L/W): 1200mm x 600mm
	Thickness	Thickness (T): 60mm
	Installation	Cut to 100mm strips, installed around aperture on top of steel bracket.

Sealants / Coatings		
5.1	Item	Protecta FR Acrylic Sealant
	Measurements	310mL tube
	Installation	<p>Installed in annular gap between separating element and duct.</p> <p>Installed to FR Board joints, between separating element and FR Boards, between FR boards and duct.</p>
5.2	Item	FIRESTOP Duct Wrap-38 with foil removed
	Measurements	Thickness / Width (T/W) 38mm x 112mm
	Installation	Strip installed in annular gap between duct and separating element, recessed 15mm from both faces.

Fixings		
6.1	Item	Screw 10g x 100mm
	Measurements	100mm

	Installation	Used to fix the FR Board to Plasterboard around duct at approximately 200mm centres
6.2	Item	Stainless steel Washer
	Measurements	OD: 32mm, ID: 6mm, Thickness 1.5mm
	Installation	Used to fix the FR Board to Plasterboard around duct at approximately 200mm centres
6.3	Item	Stainless Steel Cable Ties
	Measurements	12mm x 2000 mm
	Installation	Used to fix Ductwrap to duct at approximately 300mm centres, 150mm from the ends of the wrap
6.4	Item	Screws
	Measurements	41mm
	Installation	Used to fix steel angle to separating element at 200mm centres
6.5	Item	Stainless Steel Blind Rivets
	Measurements	10 x 5mm
	Installation	Used to fix the steel angle to duct at 200mm centres
6.6	Item	Steel Equal Angle 75mm x 75mm x 1.2mm (nominal)
	Measurements	75mm
	Installation	Used to fix the duct to the separating element on all sides of the duct

4.3 Specimen 2: Hatch

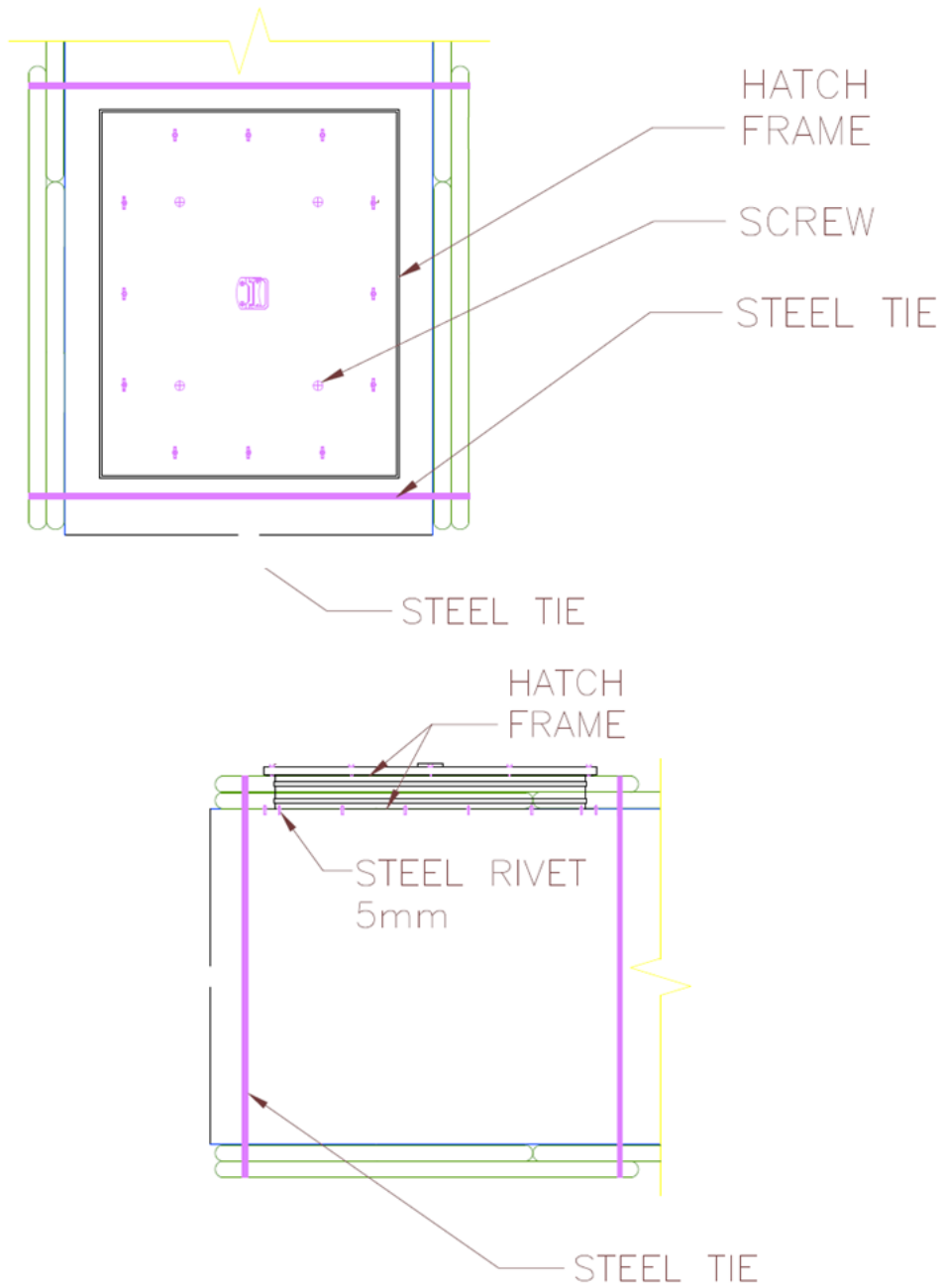

Figure 2 – Hatch installation

Specimen		
2.1	Item	Firestop Duct Hatch 600x450mm
	Measurements	Overall Width / Height / Thickness (W/H/T): 640mm x 790mm x 110mm Opening Width / Height (W/H): 450mm x 600mm
	Specimen Support	Fixed directly to ductwork
	Aperture Size	450mm x 600mm
	Installation	<p>The hatch was fixed to the top side of the duct 1800mm from the separating element. The edges of the hatch were no less than 100mm from any edges of the duct.</p> <p>The hatch was fixed to the duct using rivets at approximately 150mm centres around the hatch. The aperture within the hatch was then cut out.</p> <p>One layer of the duct wrap was installed around the hatch, butting into the hatch webbing. Each length of wrap was butt-joined to the previous length.</p> <p>An additional layer of wrap was installed around the perimeter of the hatch, measuring 100mm from all edges of the hatch. Layers of wrap were secured with cable ties at either end of the hatch where the second layer of wrap finished.</p>

Wrap		
3.1	Item	FIRESTOP Duct Wrap-38 – foil faced ceramic fibre blanket
	Measurements	Thickness / Width / Length (T/W/L): 38mm x 600mm x 7200mm
	Density	96 kg/m ³
	Installation	<p>Used to wrap the Air duct on unexposed face.</p> <p>1st layer: installed around the duct and hatch, butting up against the hatch webbing. Each length of wrap was butt-joined to the previous length.</p> <p>2nd layer: 170mm strips installed into the hatch flanges around the perimeter of the hatch, measuring 100mm from all edges of the duct</p>

Fixings		
6.3	Item	Stainless Steel Cable Ties
	Measurements	12mm x 2000 mm
	Installation	Used to fix Ductwrap to duct at approximately 300mm centres, 150mm from the ends of the wrap
6.5	Item	Stainless Steel Blind Rivets
	Measurements	10 x 5mm
	Installation	Used to fix the hatch to duct at 150mm centres

5. Additional temperature measurements

Additional thermocouples were installed to assess the performance of the duct wrap protection at different distances from the wall.

Layers of wrap	From the wall, mm	Maximum temperature rise, deg C			
		30 min	60 min	90 min	120 min
1	1200	82	177	228	240
	1200	64	161	189	197
2	25	37	120	166	180
	25	17	69	170	178
	400	30	105	152	155
	400	16	66	129	133
	1900	59	119	141	157
	1900	59	132	150	149

6. Permissible variations to the tested specimen

A test result obtained for the largest air duct in the range may be applied to all air ducts of the same type (including any aspect ratio), provided the maximum dimensions do not exceed those tested and that the components remain in the same orientation as that tested.